

## **APPENDIX C OPTION BOARDS**

### **C.1 Introduction**

This appendix explains how to install either the extended buffer board option or the Kanji character set board option. Both option boards use the same logic board connector; therefore, the plotter can be operated with only one option board installed at a time. Refer to Paragraph 1.11 for general information about the extended buffer board.

### **C.2 Option Board Installation Instructions**

#### **NOTE**

Houston Instrument's limited warranty does not cover repair of option boards damaged by customer abuse, accident, misuse, or incorrect installation. A Houston Instrument dealer or qualified technician should install your option board.

1. Be sure the plotter's power switch is set to OFF. Unplug the plotter's ac cord from the ac wall outlet and from the plotter's ac receptacle.
2. Remove the pen changer or scanner accessories from the plotter, if installed. Remove any pen from the pen holder and any chart from the plotter. Disconnect the data cable from the plotter. Remove the plotter from its stand.
3. Lower both pinch roller arms. Place the plotter upside-down on a soft cloth on a flat surface.
4. Remove the screws shown in Figure C-1 and remove the bottom cover.

## OPTION BOARDS

---

### C-2

5. Place the option board over the plotter logic board with the component side up, but do not attempt to install it at this time. Turn the option board so that its connector J1 is on the same end of the logic board as the logic board connector P8 (the row of large pins). Note that there are six holes in the buffer option board and four holes in the Kanji option board with corresponding holes in the logic board. These holes are for the snap-in plastic standoffs. See Figure C-2.
6. Remove the option board and insert the snap-in standoffs into the corresponding holes in the front side (the component side) of the logic board. Six standoffs are required for the buffer board; four standoffs are required for the Kanji board.
7. Again place the option board over the plotter logic board with the component side up. Align connector J1 on the left side of the option board with connector P8 on the left side of the logic board (the row of large pins). Maintaining connector alignment, **CAREFULLY** and **SLOWLY** press the option board downward until you see the pins push through the option board connector. Then press downward on the edges of the option board to snap the standoffs into the option board.
8. Place the bottom cover on the plotter. Install the bottom cover screws and washers, but do not tighten them at this time. Locate the bottom cover opening for the DB-25 data connector. Slide the bottom cover to the left as far as possible so that the DB-25 connector is fully exposed and centered in the opening. Maintaining this position, tighten the bottom cover screws.
9. Mount the plotter on its stand. Attach the ac cord to the plotter ac receptacle and the ac wall outlet. Connect the data cable to the plotter. If previously removed, install the pen changer and/or scanner accessories on the plotter.

The function of either option board can be toggled on and off by using the DM/PL or HPGL *OPTION BOARD* menu parameter (see Paragraphs 2.5 and 2.6).

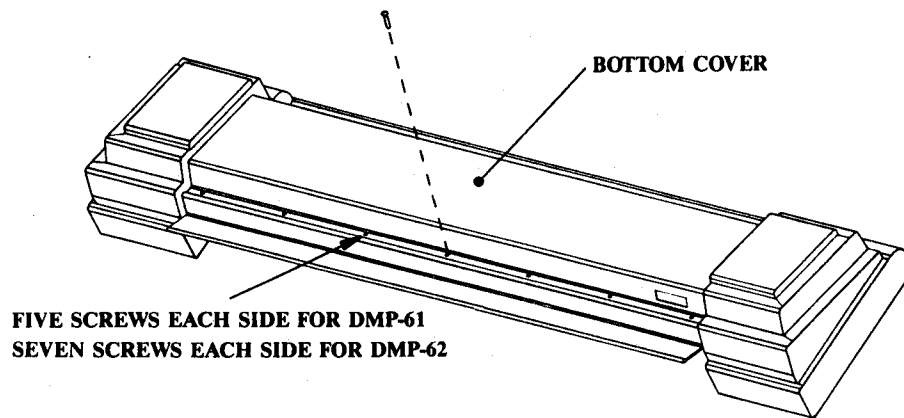

**FIGURE C-1. BOTTOM VIEW OF PLOTTER**

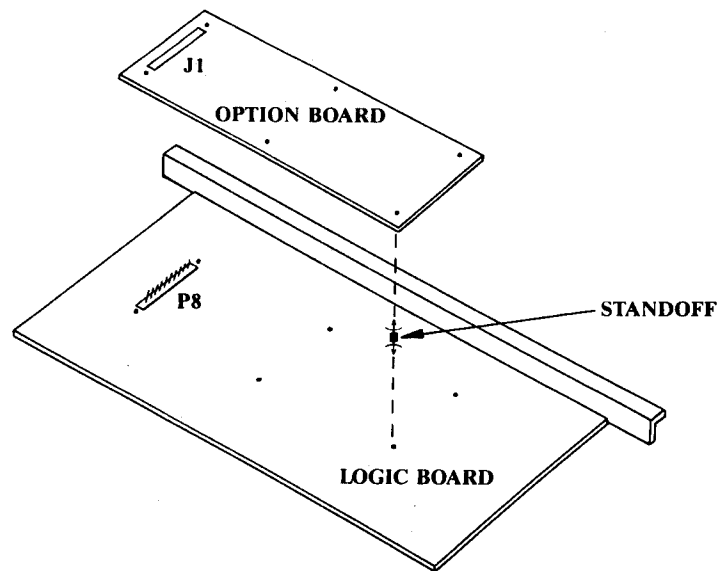

**FIGURE C-2. OPTION BOARD**

## APPENDIX D

### OPERATING CONDITIONS FOR PLOTTING MEDIA

Although the plotter's approved environmental operating range is 40° to 95° F (4.5° to 35° C) at 20% to 95% relative humidity, extreme high or low temperature and humidity conditions may cause the plotting media to expand or contract.

Figure D-1 shows the recommended operating range for all sizes of film and for vellum and paper chart sizes Engineering A, Engineering B, Architectural A, Architectural B, A4 DIN, A3 DIN, Oversize A4, and Oversize A3.

Figure D-2 shows the recommended operating range for vellum and paper chart sizes Engineering C, Engineering D, Engineering E, Architectural C, Architectural D, Architectural E, A2 DIN, A1 DIN, A0 DIN, B1 DIN, Architectural /Engineering F, Architectural 30 × 42 inches, Oversize A2, Oversize A1, and Oversize A0.

If the plotting media is being used in an extreme operating condition, you may have to load the larger size charts differently than explained in Paragraph 1.7. The following paragraph explains how.

Under normal operating conditions, a chart should be aligned with the white line on the right end of the platen and the groove on the platen extension as explained in Paragraph 1.7. However, if the chart has contracted, you must center the chart between both pinch rollers so that the pinch roller wheels make contact with the edges of the chart. If the chart has expanded, you must move the chart to the right so that it does not make contact with the left pinch roller assembly during paper shuffle.

# OPERATING CONDITIONS FOR PLOTTING MEDIA

D-2

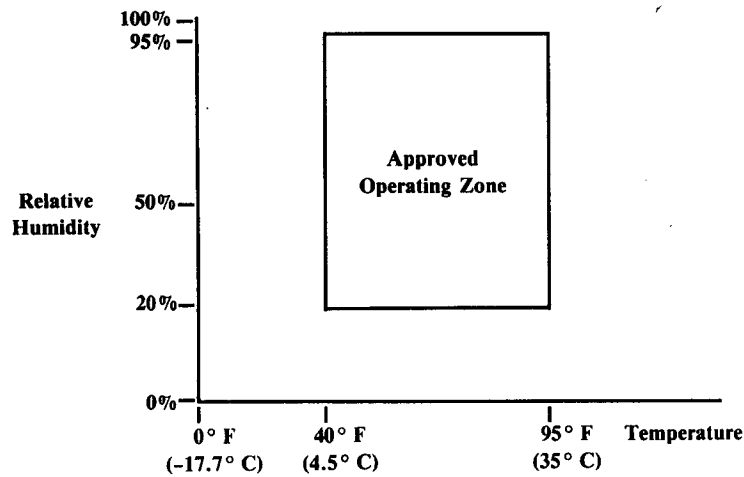

**FIGURE D-1.**  
**OPERATING RANGE FOR ALL FILM AND SMALL CHART PAPER**

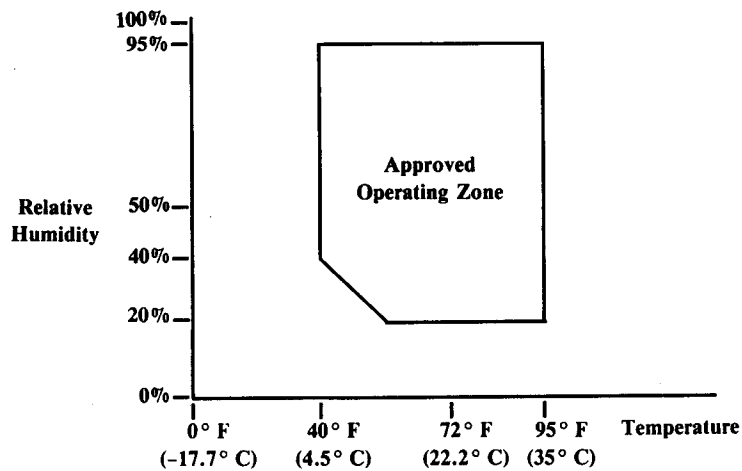

**FIGURE D-2.**  
**OPERATING RANGE FOR LARGE CHART PAPER AND VELLUM**

## **APPENDIX E INTERFACE NOTES FOR DMP-60 SERIES PLOTTERS**

The following paragraphs describe communication between a computer and the plotter. These notes are arranged by computer configuration, and contain the following information, where pertinent.

- **Cable Specifications.** A cable specification is given for the plotter. The exact pin-for-pin description is detailed, as well as the type of connector needed on each cable end. These cable definitions establish a communications link between the computer and plotter and provide hardware handshake capability. Refer to Paragraph 1.9 for further information about the serial RS-232-C interface.

### **NOTE**

The cable specifications described are general purpose and work with most software packages. Before using these cable specifications, however, you should consult your software documentation. If the software package requires a unique cable specification, it will be listed in the software documentation.

- **System Setup.** Instructions may be given to set up the computer's serial port. This setup is necessary to run the plotter with the computer. Information about setting up baud rate, parity, handshake mode, and pass-through port parameters for the plotter are given in Paragraph 2.4.
- **Communication And Handshaking.** A BASIC program may be given that draws 1500 circles horizontally across the chart. The purpose of this program is to demonstrate the communications and handshaking abilities of the plotter and computer.

# INTERFACE NOTES FOR DMP-60 SERIES PLOTTERS

---

E-2

## E.1 Apple Macintosh 512K Enhanced With A 9-Pin Serial Port

- Cable Specifications:

Plotter	Computer
DB-25S Connector	DB-9P Connector
2 TD _____	9
3 RD _____	5
4 RTS _____	7
7 GND _____	3
(1, 5, 6, and 8-25 are not connected.)	(1, 2, 4, 6, and 8 are not connected.)

## E.2 Apple Macintosh Plus, Macintosh SE, Or Macintosh II With An 8-Pin Serial Port

- Cable Specifications:

Plotter	Computer
DB-25S Connector	8-Pin (Male) DIN Connector
2 TD _____	5
3 RD _____	3
4 RTS _____	2
7 GND _____	4
(1, 5, 6, and 8-25 are not connected.)	(1, 6, 7, and 8 are not connected.)

## E.3 IBM AT Or Compatible Computer With A 9-Pin Serial Port

- Cable Specifications:

Plotter	Computer
DB-25S Connector	DB-9S Connector
2 TD _____	2
3 RD _____	3
4 RTS _____	8
7 GND _____	5
(1, 5, 6, and 8-25 are not connected.)	(1, 4, 6, and 9 are jumpered together.) (7 is not connected.)

Houston Instrument cable number HR29-483 corresponds to this cable definition.

- System Setup:

**NOTE**

The following setup information assumes that you are using PC-DOS.

1. Boot up the operating system.
2. After the system prompt, issue the following command to configure the serial port:

MODE COM1:9600,N,8,2,P

3. After the system prompt, issue the following command to redirect output to the serial port:

MODE LPT1:=COM1:

# INTERFACE NOTES FOR DMP-60 SERIES PLOTTERS

---

E-4

4. The computer end of the cable must be connected to the serial port defined as COM1. The plotter menu must be set for baud rate of 9600, parity of NONE, BIT 8=0, and RTS/DTR mode of TOGGLE.

- Communications And Handshaking:

**NOTE**

The following BASIC program assumes that you are using IBM's BASICA or Microsoft's GWBASIC.

1. After the system prompt, issue the command to load BASIC. For more information about loading BASIC, consult your computer documentation.
2. After loading BASIC, type in the following program:

PROGRAM	COMMENTS
10 LPRINT ";; A H O V2 P1 200,200"	selects the plotter
20 FOR X=300 TO 15300 STEP 10	defines x coordinate of center
30 LPRINT "CC ";X;","300 100 "	outputs series of 1500 circles
40 NEXT	
50 END	

3. To save the program, issue the following command:

SAVE "PLOTTEST.BAS"

4. You may now run the program. Issue the following command:

RUN

5. To load and run the program at a later date, issue the following command:

RUN "PLOTTEST.BAS"

## E.4 IBM PC, IBM PC/XT, IBM PS/2, Or Compatible Computer With A 25-Pin Serial Port

- Cable Specifications:

Plotter	Computer
DB-25S Connector	DB-25S Connector
2 TD _____	3
3 RD _____	2
4 RTS _____	5
7 GND _____	7
(1, 5, 6 and 8 through 25 are not connected.)	(6, 8, 20, and 22 are jumpered together.) (1, 4, 9-19, 21, and 23 are not connected.)

Houston Instrument cable number HR29-316 corresponds to this cable definition.

- System Setup:

### NOTE

The following setup information assumes that you are using PC-DOS.

1. Boot up the operating system.
2. After the system prompt, issue the following command to configure the serial port:

MODE COM1:9600,N,8,2,P

3. After the system prompt, issue the following command to redirect output to the serial port:

MODE LPT1:=COM1:

# INTERFACE NOTES FOR DMP-60 SERIES PLOTTERS

---

E-6

4. The computer end of the cable must be connected to the serial port defined as COM1. The plotter menu must be set for baud rate of 9600, parity of NONE, BIT 8=0, and RTS/DTR mode of TOGGLE.

- Communications And Handshaking:

### NOTE

The following BASIC program assumes that you are using IBM's BASICA or Microsoft's GWBASIC.

1. After the system prompt, issue the command to load BASIC. For more information about loading BASIC, consult your computer documentation.
2. After loading BASIC, type in the following program:

PROGRAM	COMMENTS
10 LPRINT "": A H O V2 P1 200,200"	selects the plotter
20 FOR X=300 TO 15300 STEP 10	defines x coordinate of center
30 LPRINT "CC ";X;,"300 100 "	outputs series of 1500 circles
40 NEXT	
50 END	

3. To save the program, issue the following command:

SAVE "PLOTTEST.BAS"

4. You may now run the program. Issue the following command:

RUN

5. To load and run the program at a later date, issue the following command:

RUN "PLOTTEST.BAS"