

---

## QUICK START

### 0.1 INTRODUCTION

Congratulations on your purchase of a Houston Instrument™ DMP-60 series plotter. We know that you will find this to be a useful graphics tool and that you will receive many years of service from it.

We also realize that most of us like to put our new computer accessories to work as soon as possible. The DMP-60 series plotters have been carefully designed for both easy installation and easy use. That's what these instructions are all about. In most cases, you can use the following directions and have the plotter operating with your computer and plotting software very quickly. Although specific AutoCAD™ and VersaCAD® setup information is provided in this section, the concepts can be applied to any software package being used with the plotter.

Please keep in mind that these directions are simply intended as a quick way to help you use your new plotter. If you have any difficulty, the directions will refer you to other parts of this manual. In any case, be sure to read the entire manual after installation so that you can learn about all of the capabilities and features of your new plotter.

## 0.2 WHAT YOU WILL DO

Using this Quick Start Section, you will learn how to:

- Assemble and install the plotter,
- Set the chart size and load a chart,
- Install a pen,
- Verify plotter operation,
- Use the plotter menu to configure the plotter,
- Set up the plotter for use with either AutoCAD or VersaCAD,
- See where to get help in case of hardware or software problems.

## 0.3 ASSEMBLY AND INSTALLATION

- Unpack the plotter and accessories from the shipping box.
- Look at the power entry module on the bottom of the plotter. Your plotter may be equipped with either of two power entry modules. One module uses a pin to indicate the plotter's voltage setting (see Figure 0-1). The other module uses a numbered voltage select board inside the fuse cavity (see Figure 0-1). Be sure the number visible matches the line voltage at your site. If not, refer to Paragraph 5.2.
- Assemble the plotter stand and attach the plotter to the stand using the instructions packed with the stand.

**CAUTION**

Do not operate the plotter until after you have assembled the floor stand and attached the plotter to it. Otherwise, damage to the plotter or the plotting materials can result.

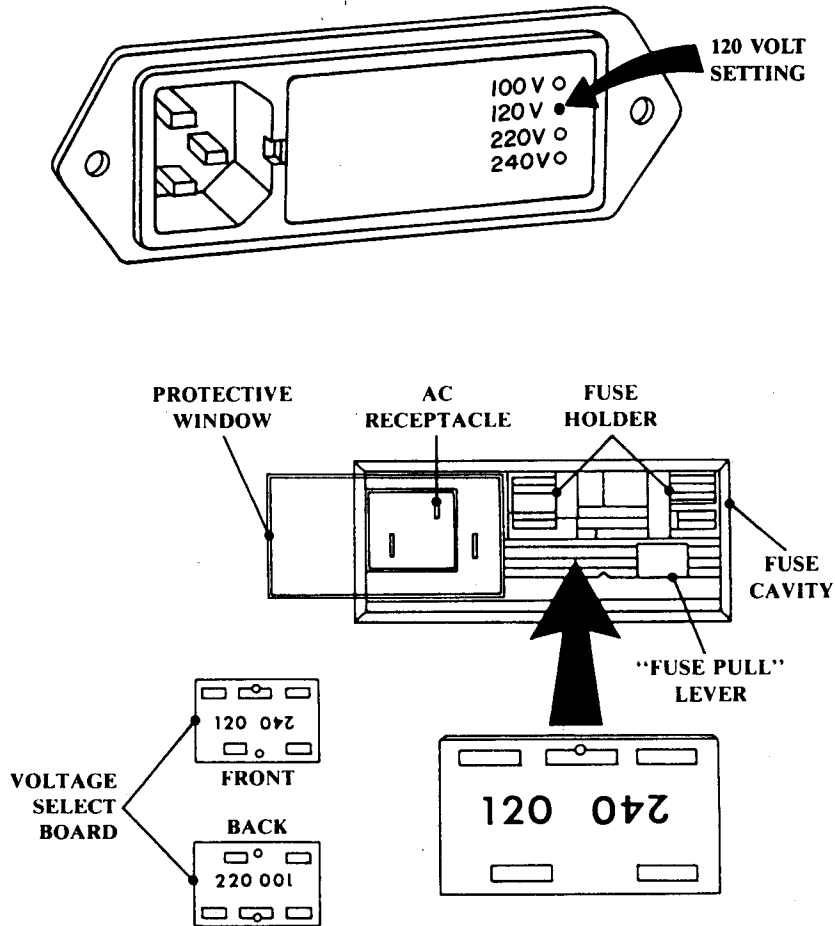
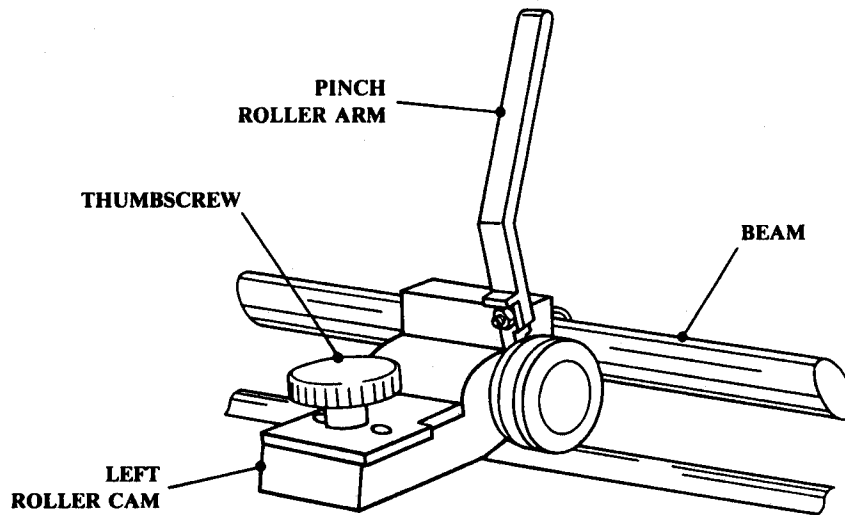

**FIGURE 0-1. EXAMPLE 120 VOLT SETTING**

- Connect the power cord to the plotter and power source.
- Find the power switch on the front of the plotter and set it to ON to power on the plotter. (After the plotter initializes, the RESET and LOAD LEDs will blink on and off.)

## 0.4 CHART SIZE SETTING

- Raise the left pinch roller arm. See Figure 0-2.



**FIGURE 0-2. LEFT PINCH ROLLER ASSEMBLY AND THUMBSCREW**

- Loosen the thumbscrew on the left pinch roller.
- Slide the left pinch roller to the threaded hole position on the platen that matches your chart size, then tighten the left pinch roller thumbscrew. See Figure 0-3.

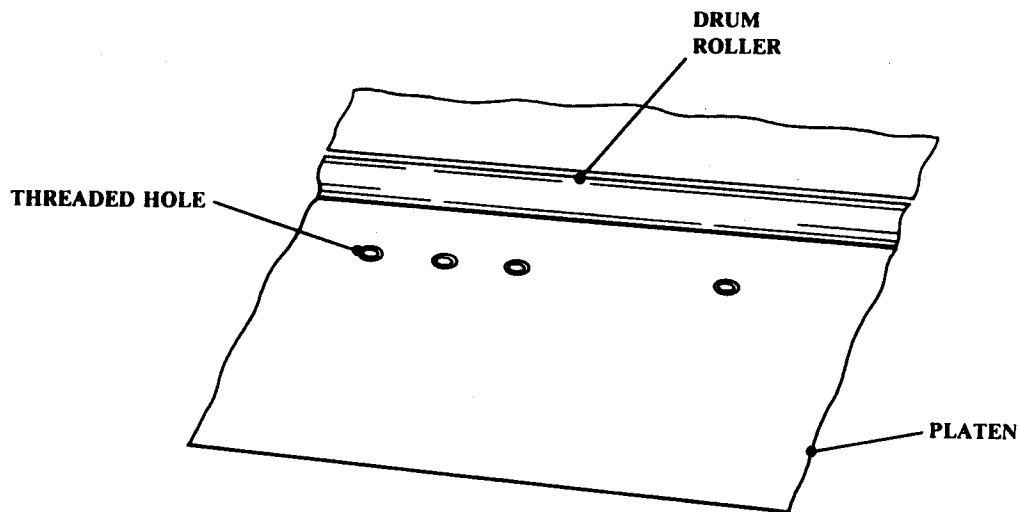
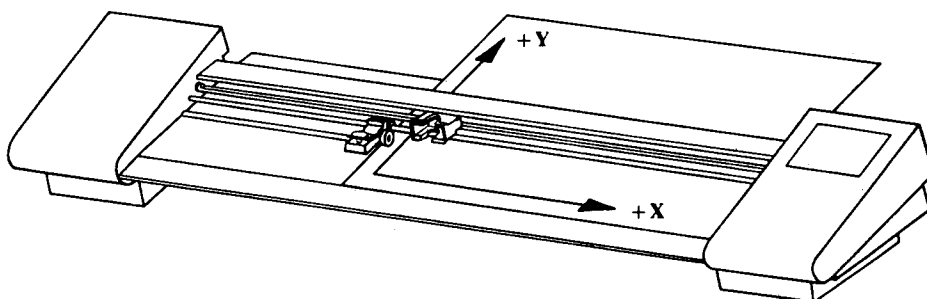

**FIGURE 0-3. THREADED HOLES ON PLATEN**

If you had any difficulty with chart size setting, refer to Paragraph 1.7.

## 0.5 CHART LOADING

- Raise the right pinch roller arm.
- Slide the chart under the pinch rollers so that its right edge aligns with the inside of the white line on the right side of the plotter and the front edge of the chart aligns with the groove on the front of the plotter. Then close both pinch roller arms. See Figures 0-4 and 0-5.



This example shows size C media loaded (left pinch roller assembly in position 5 and the pen holder at left plot origin).

Align the edge of the chart with the groove on the platen and the white line on the right side of the platen.

**FIGURE 0-4. LOADING SMALL CHARTS**

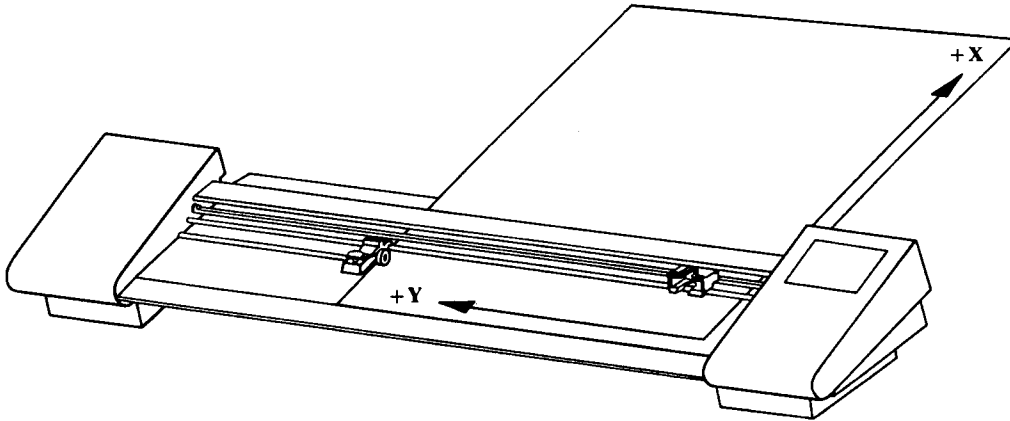

This example shows size D media loaded (left pinch roller assembly in position 5 and the pen holder at right plot origin).

Align the edge of the chart with the groove on the platen and the white line on the right side of the platen.

#### **FIGURE 0-5. LOADING LARGE CHARTS**

- Press the control panel LOAD switch to load the chart.

If you had any difficulty with chart loading, refer to Paragraph 1.7.

## 0.6 PEN INSTALLATION

- Prepare the disposable technical drafting pens using the instructions packed with the pens.
- Install the pen in the plotter pen holder.

Refer to Paragraph 1.8 for more information if you had any trouble with the pen.

## 0.7 DATA CABLE CONNECTION

- If you have purchased a data cable, connect it to the data connector on the back of the plotter and to the host computer. Refer to Figure 1-1 to identify the data connector.
- If you are making your own data cable, then refer to your plotting application software manual for any particular cabling requirements. Also, refer to Paragraph 1.9 and Appendix E for more information. If your computer is not listed in Appendix E, refer to the software package's cabling requirements for your particular computer.

## 0.8 OPERATIONAL CHECK

- Press the control panel LOCAL key once to place the plotter in local mode.
- Simultaneously press the control panel ▼ and ▲ keys to start the customer confidence test plot. Refer to Figure 0-6.
- Successful completion indicates that the plotter is operational.
- Open the left and right pinch roller arms and remove the chart.

**DMP-60 Series**

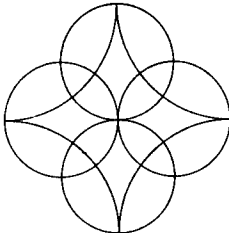
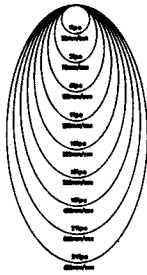
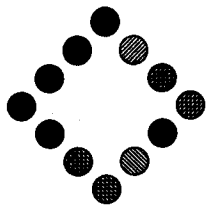
<p><b>Quality &amp; Reliability</b></p> <p>Accuracy: +/-0.01" or 0.2% of move        +/-0.25mm or 0.2% of move        Repeatability: +/-0.002" (single pen)        +/-0.05mm (single pen)        Resolution: 0.0005"        0.0127mm        High Speed Smooth Curve Generator</p> 	<p><b>Increased Throughput</b></p> <p>Velocity: DMP-61: 32 ips (metric)        800 mm/sec (metric)        DMP-62: 24 ips (metric)        600 mm/sec (metric)        Acceleration: DMP-61: 4 g        DMP-62: 2 g</p> 
<p><b>Extensive Features</b></p> <p>Media sizes: DMP-61: A - B        A4 - A1 metric        DMP-62: A - B, L, F, 3R/4R        A4 - A1 metric</p> <p>Software compatibility: DM/PL or HPGL        Filled font &amp; closed figure capability        Choice of pen &amp; media types        Multiple fonts        Proportional &amp; non-proportional text spacing        Character sets including:</p> <p>ASCII:        ABCDEFGHIJKLMNOPQRSTUVWXYZ        Japanese (Katakana):        アイウエオカキクケコサシスセソ        Greek:        ΑΒΓΔΕΖΗΘΙΚΑΜΝΟΡ ΡΙΤΒΩ ΞΥΖ</p>	<p><b>Add-On Capability</b></p> <p>Automatic eight pen changer        Optical scanner        1 Megabyte buffer or Kanji character set        Priority Response Overnight Service (U.S. only)        800-254-4786 or in Texas 800-252-0000</p> 

**HOUSTON INSTRUMENT**  
 A Division of Summagraphics

Service, supplies, technical support: 1-800-444-3425

FIGURE 0-6. CUSTOMER CONFIDENCE TEST PLOT

## 0.9 USING MENU MODE

The following exercise shows you how to use the plotter's menu mode to minimally configure the plotter and select the active plotting language. The plotter can operate with either DM/PL™ or HPGL as the active plotting language. DM/PL or HPGL is selected by entering and exiting the respective menu. The active plotter language (DM/PL or HPGL) is the one whose menu was most recently used.

It is important to note that the plotting language active in the plotter **MUST** match that of the plotting software you are using. That is, you must enable the desired plotting language in the plotter and select the appropriate plotter type with your plotting software. To use DM/PL, for example, select DM/PL as the active plotting language in the plotter, then select a Houston Instrument DMP-60 (or DMP-50) plotter as the plotting device in your software. To use HPGL, select HPGL as the active plotting language in the plotter, then select an HP™ 758X plotter as the plotting device in your software.

### NOTE

The DM/PL and HPGL menus have several identical parameters. However, these menus are independent and are separately maintained in the plotter. This means that changing a parameter in one menu **DOES NOT** change any corresponding parameter in the other menu. This is a feature to allow you to maintain separate configurations for DM/PL or HPGL use. For example, if you change the DM/PL menu *BAUD RATE* parameter, the *BAUD RATE* parameter in the HPGL menu is **NOT** changed.

- Place a B-size (DIN A3) chart (or larger) under the pinch rollers so that the front of the chart is aligned with the groove on the front of the plotter and the right edge of the chart is aligned with the inside of the white line on the right side of the plotter, then close both pinch roller arms.
- Press the control panel **LOAD** key to load the chart.

- If you wish to configure the plotter for DM/PL operation, then go to Paragraph 0.9.1 and perform the steps listed. To configure the plotter for HPGL operation, go to Paragraph 0.9.2 and perform those steps. If you perform both configurations, do **LAST** the one that you wish to be active. Remember, the active plotter language (DM/PL or HPGL) is the one whose menu was most recently used.

**AFTER** the plotter has been configured for both DM/PL and HPGL, you can easily change the active plotting language. First, load a B-size (DIN A3) or larger chart. To activate DM/PL, press the ENTER key, press the SCALE UR key, then press the SCALE UR key after the option select line is plotted. To activate HPGL, press the ENTER key, press the CLIP UR key, then press the CLIP UR key after the option select line is plotted.

### 0.9.1 Configuring DM/PL

- Press the control panel ENTER key and then the SCALE UR key to activate DM/PL Menu Mode. The plotter then plots the DM/PL option select line. When the plotter parks the pen over *help*, press the ENTER key to plot the help listing. Using the control panel ◀ and ▶ keys, move the pen over *list* in the option select line, then press the ENTER key to list the presently selected (underlined) menu options.
- Using the control panel ◀ and ▶ keys, move the pen over the *15* in the option select line; then press the ENTER key. The pen then moves to the presently selected baud rate. Using the ◀ and ▶ keys, move the pen over the baud rate that matches your plotting software baud rate requirement and press the ENTER key.
- Using the control panel ◀ and ▶ keys, move the pen over the *16* in the option select line and then press the ENTER key. The pen then moves to the presently selected parity setting. Using the ◀ and ▶ keys, move the pen over the parity setting that matches your plotting software parity requirement and press the ENTER key.

- Using the control panel ◀ and ▶ keys, move the pen over the *17* in the option select line; then press the ENTER key. The pen then moves to the presently selected RTS/DTR handshake mode. Using the ◀ and ▶ keys, move the pen over the handshake mode that matches your plotting software requirement and press the ENTER key. In general, select *TOGGLE* for hardware handshaking or *ALWAYS HIGH* for software handshaking.
- Press the control panel SCALE UR key or CLIP UR key to exit DM/PL menu mode. DM/PL is now the active plotting language.
- Open the left and right pinch roller arms. Remove and save the plotted menu.
- If configuring the plotter for HPGL also, then go to Paragraph 0.9.2. If not, then go to Paragraph 0.10.

## 0.9.2 Configuring HPGL

- Press the control panel ENTER key and then the CLIP UR key to activate HPGL menu mode. The plotter then plots the HPGL option select line. When the plotter parks the pen over *help*, press the ENTER key to plot the help listing. Using the control panel ◀ and ▶ keys, move the pen over *list* in the option select line, then press the ENTER key to list the presently selected (underlined) menu options.
- Using the control panel ◀ and ▶ keys, move the pen over the *15* in the option select line; then press the ENTER key. The pen then moves to the presently selected baud rate. Using the ◀ and ▶ keys, move the pen over the baud rate that matches your plotting software baud rate requirement and press the ENTER key.
- Using the control panel ◀ and ▶ keys, move the pen over the *16* in the option select line and then press the ENTER key. The pen then moves to the presently selected parity setting. Using the ◀ and ▶ keys, move the pen over the parity setting that matches your plotting software parity requirement and press the ENTER key.

- Using the control panel ◀ and ▶ keys, move the pen over the *17* in the option select line; then press the ENTER key. The pen then moves to the presently selected RTS/DTR handshake mode. Using the ◀ and ▶ keys, move the pen over the handshake mode that matches your plotting software requirement and press the ENTER key. In general, select *TOGGLE* for hardware handshaking or *ALWAYS HIGH* for software handshaking.
- Using the control panel ◀ and ▶ keys, move the pen over the *18* in the option select line, then press the ENTER key. The pen then moves to the presently selected line status. Using the ◀ and ▶ keys, move the pen over the line status that matches your plotting software requirement and press the ENTER key.
- Press the control panel CLIP UR key or SCALE UR key to exit HPGL menu mode. HPGL is now the active plotting language.
- Open the left and right pinch roller arms. Remove and save the plotted menu.
- If configuring the plotter for DM/PL also, then go to Paragraph 0.9.1. If not, then go to Paragraph 0.10.

## 0.10 AUTOCAD AND VERSACAD SETUP INSTRUCTIONS

The previous paragraphs provided you with general setup instructions for your plotter. The following paragraphs provide you with specific instructions to set up the plotter for use with AutoCAD or VersaCAD (MS-DOS™ versions) software packages.

- Enter the plotter's DM/PL menu as explained in Paragraph 0.9.1 and select the parameters listed below.

### AutoCAD:

UART Parity	set to <i>EVEN</i>
Handshake RTS/DTR	set to <i>ALWAYS HIGH*</i>
Baud Rate	leave at <i>9600</i>

\* Set this parameter to *TOGGLE* if plotting from other than AutoCAD's main menu.

### VersaCAD:

UART Parity	leave at <i>BIT8=0</i>
Handshake RTS/DTR	leave at <i>TOGGLE</i>
Baud Rate	leave at <i>9600</i>

### NOTE

The plotter's factory menu settings will work with many software packages; however, be sure to read your software manual to determine any software specific setup requirements.

- Configure the serial port as explained below.

### AutoCAD:

Choose "Configure AutoCAD" from the main software menu. Select the serial port (COM1 or COM2) to which the plotter is connected.

### VersaCAD:

Choose "Enviro" in the main software menu. Select the serial port (COM1 or COM2) to which the plotter is connected.

- Select either the DMP-61 driver or the DMP-62 driver for your specific plotter model.
- The following paragraphs provide operating considerations when using AutoCAD or VersaCAD.

**Clipping:**

Clipping occurs when the drawing size is too large to fit on the available plot area. The plot area is typically less than the media size since the mechanism that holds the media prevents the plotter from drawing on that area. The available plot areas for each media size are listed in Paragraph 1.7. Note that if you plot to scale and the scale you choose does not fit within the available plot area, the plot will be clipped.

AutoCAD lists standard media sizes rather than plot areas. To avoid clipping, set the "User" selection to the exact plot area available for the media size that you are using and select plot to "Fit." This will prevent the plot from being clipped.

VersaCAD asks for the left border and the right border, and then queries the plotter and calculates the available plot area.

**Pen Tip Width:**

If the pen tip width value in AutoCAD is not set correctly, pen drag can occur. The values for the pens are:

0.35 mm pen tip width = 0.014 inch

0.50 mm pen tip width = 0.020 inch

0.70 mm pen tip width = 0.028 inch

The pen tip width in VersaCAD can be set in the "Enviro" section of the program.

## Multi-colored Plots:

AutoCAD and VersaCAD must be told if the pen changer accessory is installed on the plotter. Otherwise, multi-colored plots will be drawn with a single pen. In AutoCAD, choose "Layer" and specify PEN NUMBER for the pen color. In VersaCAD, choose "Properties" and then choose "Pen."

### NOTE

You can also initiate the plotter's confidence test to make sure the plotter is recognizing the pen changer (see Paragraph 2.3.2). If the confidence test is drawn with multiple pens, this indicates that the software setup is incorrect.

## Stray Lines:

If your plot has stray or extraneous lines on it, follow the suggestions below.

- Run the plotter's confidence test to determine if the plotter has a mechanical problem (see Paragraph 2.3.2).
- Inspect the interface cable by removing the screws (usually two) from the connector ends and visually inspect the cable to determine if a wire has become disconnected. If you have the appropriate equipment, check the continuity of the cable.
- Check the *Handshake RTS/DTR* and *UART Parity* menu parameter selections to make sure they match your software requirements.
- Connect the plotter to another serial port on the computer, if available. If the plotter draws the plot successfully on a second serial port, the first serial port is probably malfunctioning.

**0.11 DONE**

If you had any trouble with menu mode, then refer to Paragraph 2.4 for more information.

This completes the installation, check out, and minimal configuration of the plotter. Be sure to read the remainder of the manual (these instructions are not intended as a substitute for the manual). Also, refer to your plotting application software manual if additional menu configuration of the plotter is needed. Typically, the most important configuration items are the data cable, baud rate, parity, and handshake mode (and line status for HPGL).

**0.12 HOUSTON INSTRUMENT PRODUCT SUPPORT**

Houston Instrument offers hardware and software support for all of its products. This help is only a telephone call away.

Please have the following information available when calling Houston Instrument:

- The product model number, which is printed on the bottom panel,
- The product serial number, which is printed on the bottom panel,
- The date of purchase,
- The type of maintenance agreement, if any,
- The reseller company name, contact name and phone number,
- A brief description of the question or problem.

After preparing the information requested above, you can contact Houston Instrument at 1-800-444-3425 for assistance. Your call will be received by the Call Center and routed to the Technical Support Hardware or Technical Support Software group depending on your question or problem type.

## **QUICK START**

---

**0-18**

### **0.13 HOUSTON INSTRUMENT PRODUCTS**

- Information about other Houston Instrument products is available from the Literature Department at 1-800-444-3425.

### **0.14 WARRANTY REGISTRATION**

Remember to validate your **FREE** Priority Response Warranty by calling the HI Warranty Registration Department at 1-800-444-3425 for immediate registration.

***THANK YOU FOR BUYING THIS HOUSTON INSTRUMENT PLOTTER!***